



6795-C

FROZEN BEVERAGE FREEZER

Two flavor, Floor, Gravity feed

Powerful & Versatile

High capacity two flavor floor model for frozen beverage and milkshakes

Fast Freeze Down

Patented high efficiency heat exchanger allows fast freeze down with low energy consumption

Simple Control, Easy Operation

Simple and intuitive control system makes operation and viscosity adjustment easy, swift and more precise

Low Mix Indicator

Light turns "ON" at low mix to alert operator to add mix

See-through Dispensing Door

Clear dispensing door design makes product more attractive and serves as great marketing tool

Standby & Indicator

Maintains product temperature in both mix hopper and freezing cylinder below 4.4°C (40°F) overnight; Indicator lights up during Standby

Higher capacity solution with greater flexibility to serve larger crowds alcoholic & non-alcoholic frozen drinks including milkshakes



Hopper Agitators

Maintain product consistency and prevent product separation

Self-closing Dispensing Valves

Automatically prevents product overflow after dispense

Safety Protections

- High pressure switch to prevent compressor overheating
- Thermal overload to protect from motor overheating

Light Box (Optional)

- Illuminates flavor cards to attract more business
- Changes color to indicate Low Mix and Standby

One-hand Operated Spinner (Optional)

- Adds ability to blend and offer more varieties of treats
- Allows for multi-tasking one-hand operation that helps increase productivity and reduce serving time



6795-C

FROZEN BEVERAGE FREEZER

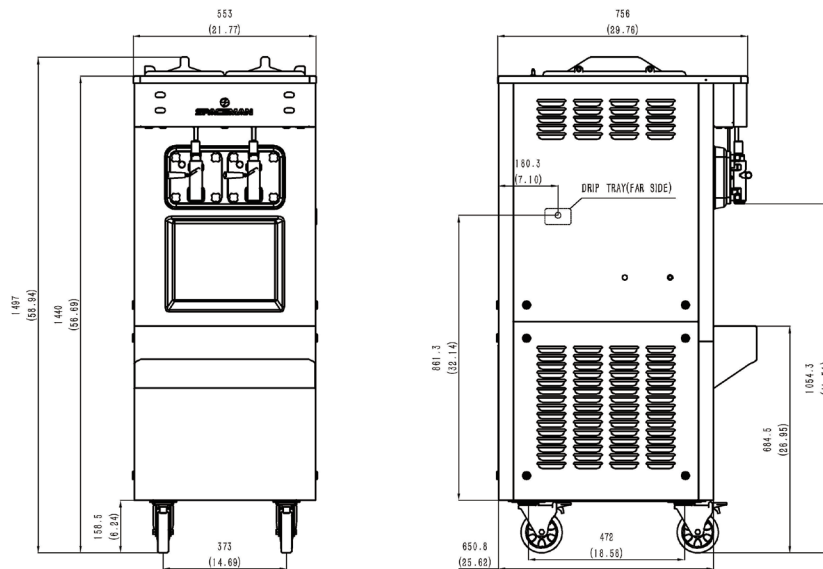

SPECIFICATIONS

Flavors	2
Freezing Cylinders	2 x 6.9L / 7.3qt
Mix Hoppers	2 x 12L / 12.7qt
Output Capacity (250 ml)	480 serves/hr
Clearance Requirements	152mm/6" on back

Weight Kg/lb

Net	250 / 551
Shipping	270 / 595
Volume	0.98 CBM / 34.75 CBF

Dimensions Net (mm/in) Shipping (mm/in)

Width	553 / 21.8	710 / 28.0
Depth	651 / 25.6	830 / 32.7
Height	1497 / 58.9	1670 / 65.7

Electrical Power (kW) Total Amps (A) Fuse (A)

220-240/50/1	4.6	22	30
208-230/60/1	5.0	24	35

FEATURES

Control Systems	Two, Mechanical
Refrigerated Hoppers	<input checked="" type="checkbox"/>
Hopper Agitators	<input checked="" type="checkbox"/>
Auto Closing Dispensing Valves	<input checked="" type="checkbox"/>
Low Mix Indicator Light	<input checked="" type="checkbox"/>
Low Mix Indicator Alarm	<input checked="" type="checkbox"/>
Standby Mode	<input checked="" type="checkbox"/>
Standby Indicator Light	<input checked="" type="checkbox"/>
High Pressure Protection	<input checked="" type="checkbox"/>
Thermal Overload Protection	<input checked="" type="checkbox"/>

AVAILABLE OPTIONS

Top Air Discharge Chute	<input checked="" type="checkbox"/>
Spinner	<input checked="" type="checkbox"/>
Light Box	<input checked="" type="checkbox"/>

• Above specifications are subject to change without notice