

BUCKEYE FIRE EQUIPMENT *Kitchen Mister* OWNER'S MANUAL

CONGRATULATIONS

You have purchased the Buckeye Fire Equipment *Kitchen Mister* Restaurant Cooking Area Fire Suppression System, the most technologically advanced and effective restaurant cooking area fire suppression system ever developed. A fire suppression system designed and produced in the USA, by one of the leading manufacturers of extinguishers and extinguishing systems. However, to guarantee the maximum effectiveness of your new Buckeye *Kitchen Mister* Fire Suppression System, you, as the owner/manager, must become familiar with your new equipment. For this purpose, we are pleased to provide you with this owner's manual.

Please note that this owner's manual is not a detailed installation, operation, and maintenance manual. This owner's manual is not intended to serve as instructions for installation or detailed service of the Buckeye Fire Equipment *Kitchen Mister* Restaurant Cooking Area Fire Suppression System, but rather to inform purchasers of this equipment as to their responsibilities in the proper usage and maintenance of this system. A copy of the detailed installation, operation, and maintenance manual, Buckeye *Kitchen Mister* Restaurant Cooking Area Fire Suppression System Technical Manual, Model BFR-TM, is available upon request from any authorized Buckeye distributor or Buckeye Fire Equipment.

APPLICATION

The Buckeye *Kitchen Mister* Restaurant Cooking Area Fire Suppression System is a pre-engineered restaurant fire suppression system, tested and listed by Underwriters Laboratories, Inc. under ULEX 6885. It meets the stringent requirements of U.L. Standard 300 and designed to comply with NFPA 17A and 96. Your authorized Buckeye installer will install your system within the UL Listed design parameters as defined in the Buckeye *Kitchen Mister* Restaurant Cooking Area Fire Suppression System Technical Manual. The following hazard areas of your kitchen must be considered for system protection:

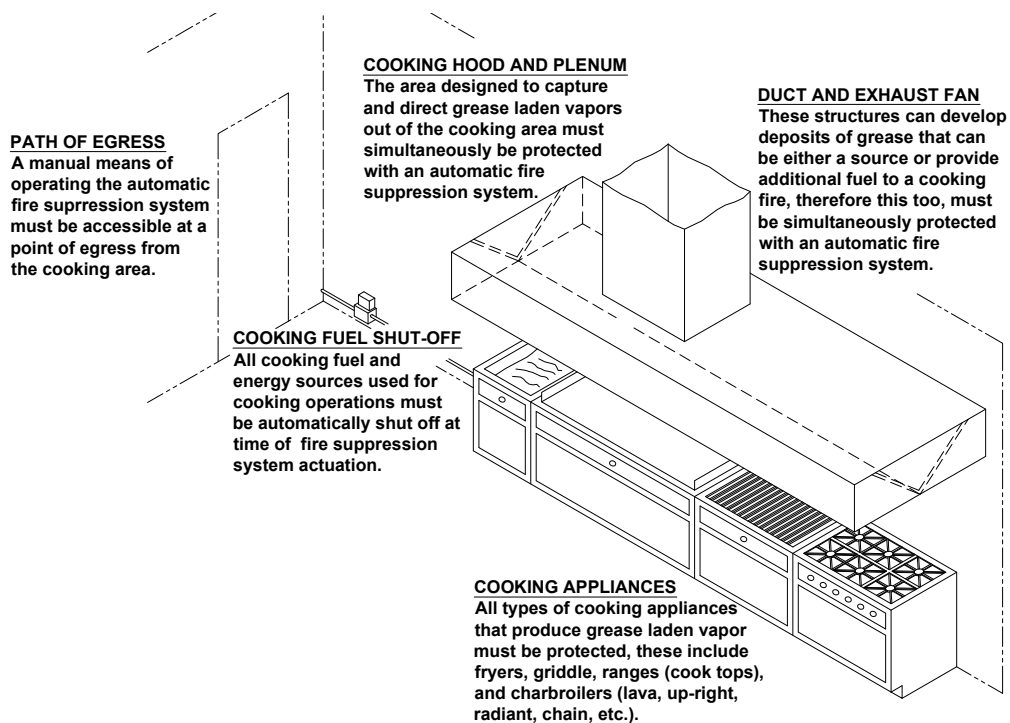

IN CASE OF FIRE

Fires can potentially start in a cooking appliance, the hood, or the duct. In case of fire, it is important that you fully understand the operation of your fire suppression system.

First: Evacuate all personnel and customers from the fire area.

Second: Call the fire department.

Third: If your fire control system has not already automatically activated, you may activate it manually by pulling the handle on the manual pull station.

Lastly: Personnel trained in the proper operation of K Class or other type of fire extinguishers may stand by, if means of easy exit are available, and provide additional fire suppression if required.

When the fire has been extinguished, and the fire department has deemed it safe to re-enter and has determined the cause of the fire, call your local authorized Buckeye Fire Equipment distributor to reset and recharge the system.

Once the equipment has cooled and it is safe to touch, clean up the discharge area using sponges with hot soapy water and detergents.

CAUTION: DO NOT USE ANY FLAMMABLE CLEANING SOLVENTS.

NOTE: It is critical to determine the cause of the fire and to correct the conditions which caused the fire prior to re-starting your operation. Under no circumstances should cooking operations be attempted before a factory trained and authorized Buckeye Fire Equipment distributor re-instate the integrity of your fire suppression system.

MAINTENANCE/INSPECTION

The Buckeye Fire Equipment *Kitchen Mister* Restaurant Cooking Area Fire Suppression System is a sophisticated fire suppression system, involving intricate mechanical components. To ensure the proper operation of the system, regular inspection and maintenance must be performed by an authorized trained Buckeye Fire Equipment distributor on a semi-annual basis, and after every periodic hood and duct cleaning (whichever occurs more frequently).

This system is made up of individual components that are listed by Underwriters Laboratories Inc, with limitations contained in the detailed installation manual. The authorized distributor must be consulted after the system is discharged or whenever changes are planned for the system and/or area of protection.

NFPA 17A and Buckeye Fire Equipment require that regularly scheduled (at a minimum of once a month) inspections of the system be conducted by the owner (or his representative). These monthly inspections are necessary to assure that the system is in proper working order and is ready when required. The following "quick review" of the Kitchen Mister System must include, but not limited to the following:

1. Determine that the cylinder, control head, gas valve, and all other components of the system are in place and has not been tampered with.
2. Determine that all appliances are still in their original position, as when the system was installed.
3. Check that the manual pull station is unobstructed and in clear view with all labeling and instructions visible.
4. Visually inspect the pressure gauge on the cylinder valve assembly to make sure the system pressure is within proper range. The yellow pointer should be in the middle of the green operable range.
5. Visually inspect the system detection lines to make sure that the cable and fusible links are not damaged, obstructed or have been moved.
6. Inspect all nozzles, making sure they are clean and free from any grease or carbon build-up. Assure that all blow-off covers are in place.
7. Check that all inspection tags or certificates are in place and up to date. A record of monthly inspections shall be maintained showing the date of the inspection, who conducted the inspection and what actions were taken if required.
8. If any deficiencies are found, call your authorized trained Buckeye Fire Equipment distributor so that the appropriate corrective action can be taken.

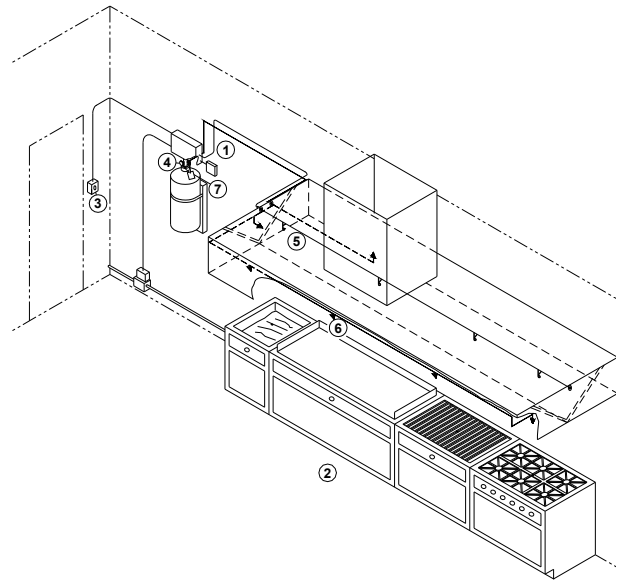

NOTE: The best method of fire prevention is good "housekeeping practices" which eliminate potential fire hazards. Inspect the overall cleanness and operation of the appliances, plenum, filters and hood. If any problems or deficiencies are found, appropriate corrective action must be taken immediately, by notifying the appropriate parties.

Confirm or schedule your semi-annual inspection and maintenance visit with your local authorized trained Buckeye Fire Equipment distributor or contact Buckeye Fire Equipment to find one servicing your area.

At this time, it is also good practice to visually inspect all hand portable fire extinguishers to verify that each is in good working condition. Refer to extinguisher's manual for detailed instructions.

MANAGEMENT RESPONSIBILITY

It makes good business sense for the owner/manager to take an interest in the following areas of his/her business operation to ensure the best possible fire protection for the restaurant:

1. Arrange for proper inspection and maintenance of the fire control system as well as hand portables.
2. Eliminate all potentially combustible materials and arrange for their proper storage.
3. Arrange for upgrading of the fire suppression system if cooking equipment is added or revised and provide protection for changes made to the ventilation system.
4. Arrange for a continuing education program in the restaurant fire suppression system operation as new employees are added to the staff.
5. Assure that good housekeeping practices have been maintained to eliminate potential fire hazards.

Remember there always is a potential fire hazard within the cooking ventilation equipment in restaurants. Many restaurants that have fires never re-open for business and many suffer severe financial loss due to lack of business continuity. Your Buckeye Fire Equipment restaurant fire suppression system is a mechanical device and, as such, requires periodic service by your distributors qualified and trained personnel.

THIS SYSTEM IS MADE UP OF UNITS TESTED WITHIN LIMITATIONS CONTAINED IN THE DETAILED INSTALLATION MANUAL. AN AUTHORIZED SYSTEM DESIGNER MUST BE CONSULTED WHENEVER CHANGES ARE PLANNED FOR THE SYSTEM OR AREA OF PROTECTION, INCLUDING THE RELOCATION OR CHANGING OF APPLIANCES. AN AUTHORIZED INSTALLER OR SYSTEM DESIGNER MUST BE CONSULTED AFTER THE SYSTEM HAS DISCHARGED.