

HSC – Design “bandraster” (flat healds) metal ceiling for applications with strong hygiene demands



Overview

The HSC high quality suspended metal ceiling complies with the highest demands in terms of hygiene, maintenance and robustness while keeping its impeccable aesthetics and stability over time.

Halton's range of so called passive ceiling is an ideal solution for rooms with strong requirements in terms of hygiene and maintenance, such as kitchens, diswashing areas or foodprocessing industry, but also hospitals or laboratories.

HSC ceilings comply with the highest hygiene requirements while offering unique architectural qualities. Its exclusive design is based on components that are all assembled together flush. The wide supporting profiles (“bandraster” or flat healds) enable in addition to increase the ceiling's panels span and width, with no compromise on stability. The number of healds and pannels is reduced. Less components, all mounted flush means less junctions where dirt can builds-up. HSC ceilings are hence easier and faster to clean.

The supporting profiles are designed to allow only few clearly identified panels to be lifted up. As long as they are in place, the other pannels can't be either removed or lifted up unintentionally. This greatly facilitates the cleaning operations, whatever their intensity.

The supporting profiles are designed to allow only few clearly identified panels to be lifted up. As long as they are in place, the other pannels can't be either removed... or lifted up unintentionally during the cleaning operations, whatever their intensity.

Only few panels marked as such can be lifted up. Thanks to the Halton's "Lift & Slide" feature, they can be easily lifted up and slid on the top of the ceiling, enabling other panels to be removed the same way. It allows for a large and quick access to the ceiling void for maintenance, without tool and especially without taking up space in the kitchen.

HSC ceilings is equipped with the Halton Skyline light fittings, also integrated flush. In its Human Centric version, Halton Skyline enables creating a lighting cycle close to that of the daylight, to improve the occupants' Wellbeing.

As an option, the ceilings' panels can be also equipped with an encapsulated acoustic insulation that directly contributes to significantly reducing the sound pressure level. The panels then improve the working conditions in noisy spaces while keeping the hygiene at the highest level.

HSC ceilings allow for the integration of multiple services such as HVAC components, emergency signs, smoke detectors, speakers etc from factory directly or on site by third parties. They are therefore equally suitable to all projects' spaces requiring a high quality suspended ceiling.

Hygiene certification

- HSC ceiling's components passed a wide variety of tests, carried out in the laboratories of the Fraunhofer Institute IPA in Stuttgart.
- Suitable to all type of spaces and requirements, from commercial kitchens to clean rooms.

Services integration

- Halton's Laminar Flow Units (LFU) that contribute to better working conditions and better air quality.
- Halton's Extraction Box (KBO) with FC aerosol separators for isolated low duty cooking appliances in kitchens. Other extraction solutions available.
- Halton Skyline (HCL) light fittings equally efficient as a culinary lighting or as Human Centric lighting, or both.
- The brandrasters (wide flat heads) can be used as cable trays.
- Other services or preparation for site services integration on request.

Other main features

- Constructed from stainless steel or aluminium, anodised or painted.
- Low height ceiling with supporting of brandraster-type (wide flat heads) for the highest stability. No need of reinforcement profiles.
- All components mounted flush.
- Easy to clean. Quick access to the ceiling void for maintenance.
- No traditional support profiles excepting for the connection to the walls. Optional wall connection profile of "cove" type.
- Easy to clean. Quick access to the ceiling void for maintenance.
- Earthquake-proof quick connectors.
- Multiple customization possibilities on shapes and finishes.

Highest hygiene and design standard

Suitable for kitchens and foodprocessing up to cleanrooms



Together with the metal ceilings' design specification, the material used and its surface properties are of great importance in areas with strong hygiene requirements. HSC metal ceiling has been developed according to the directives and rules of the GMPs (Good Manufacturing Practices) and the recommendations of EHEDG foundation's (European Hygienic Engineering and Design Group).

The HSC metal's ceiling design and manufacturing provisions first greatly limit the build-up of contaminants on its surface. To reach that goal, all its components, including the wide flat supporting healds, are assembled metal-to-metal and in a flush way. The whole visible surface is flat, without any protruding

connecting elements (such as T profiles, rivets or screws) which represent a risk of dirt build-up, difficult to remove during cleaning. By using wider panels of greater span, the proportion of joints is significantly lower compared to classic ceilings.

The metal used for HSC ceilings' manufacturing, and its surface properties, are the second key point to match the strongest hygiene requirements. It should not only facilitate regular cleaning operations but also to not be itself a source of contaminants. The paint has been carefully selected to get a smooth and homogeneous surface with a high resistance, mechanical and chemical for an efficient and safe use of common cleaning and disinfectant agents. The paint itself should also not release particles or gas, neither favor the proliferation of fungi or bacteria.

Certification

Halton HSC ceiling underwent and passed a wide variety of tests, which were carried out in the laboratories of the Fraunhofer Institute IPA in Stuttgart as shown below. HACCP International certification is pending.

Till clean rooms

Designed to match the hygiene requirements of kitchens, dish washing areas or food processing industries, HSC ceiling is suitable to any other application with architectural or hygiene challenges, till clean rooms. In that case, the only difference is that the components' junction have to be treated with a specific sealant.

Test	Standard	Category	Classification/Rating	
Particles emission	ISO 14644-1	-	Air cleanliness class	1 (lowest emissions)
Gas emission	ISO 14644-8	VOC SVOC Amines Organophosphates Siloxanes Phthalates	ISO-ACC _m class	Undetectable Undetectable Undetectable Undetectable Undetectable Undetectable
Chemical resistance	VDI 2083, sheet 17	Formalin 37% Ammonia 25% Hydrogen peroxide 30% Sulfuric acid 5% Phosphoric acid 30% Peracetic acid 15% Hydrochloric acid 5% Isopropanol 100% Sodium hydroxide 5% Sodium hypochlorite 5%	Classification after 24h exposure time	Excellent Excellent Excellent Excellent Excellent Good Excellent Excellent Excellent Excellent
Biological behaviour	ISO 846	Fungi (Method A) Bacteria (Method C)	Classification	None Excellent
Hydrogen Peroxide absorption & desorption	VDI 2083, sheet 20	H ₂ O ₂	ø k-value [min]	Non-absorptive

Acoustic ceiling

Improved acoustic comfort and discussions' intelligibility

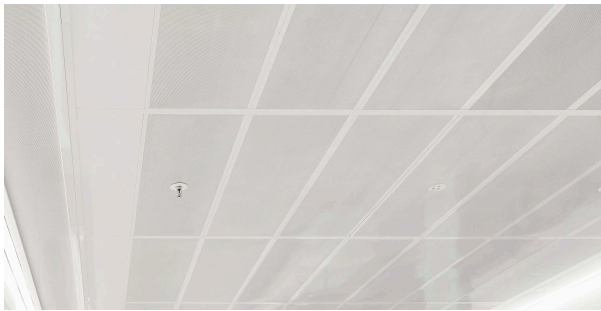

In areas with strong hygiene demands, the surfaces of the walls, floors and ceilings are usually very hard and smooth, in order to efficiently prevent contaminants settling on it and make them easier to remove during cleaning operations. The inconvenience is that it creates a very reflective space for the noise. Porous and open-pored materials and surfaces are indeed required to get a good acoustic comfort.

The HSC ceiling's optional acoustic panels combine hygiene with efficient sound attenuation properties and directly contribute to a better acoustic comfort.

Benefits

- Significant improvement of the sound absorption by the ceiling and reduction of the reverberation time.
- Improvement of speech intelligibility and acoustic quality of rooms Max use temperature of up to +100°C.
- Sandwich construction for all parts to be easy to dismantle and clean.
- Detergents resistant.
- B1 class fire protection.
- Option for consistent wall panels to increase the absorption surface.
- No breeding ground for microorganisms.

How does it work?

- The acoustic insulation is made of closed-cell, low-density polyethylene foam. It is

specifically for humid environment or steam exposures.

- The sound waves penetrate the insulation through the panels perforated front. The acoustic energy then largely convert into heat.
- The panels' back plate reflects what remains of the sound waves back into the foam, to further increases its absorption.
- The higher the degree of absorption of the acoustic insulation, the higher the sound absorption.

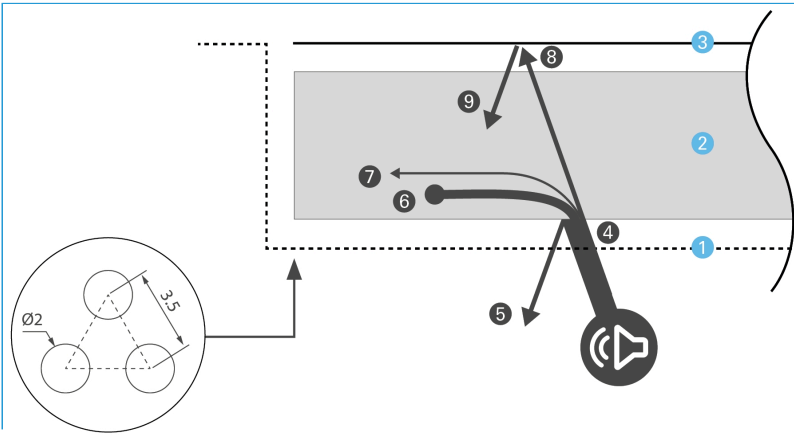

(1) Panels' perforated front – (2) Acoustic insulation – (3) Reflection plate
When reaching HSC acoustic panel, the energy of the incident sound wave (4) is split into the following components: the reflected sound (5), the absorbed sound (6), the sound transmitted by conduction (7) and the transmitted sound (8). The transmitted sound is reflected back to the acoustic insulation (9) thanks to the panel's back plate.

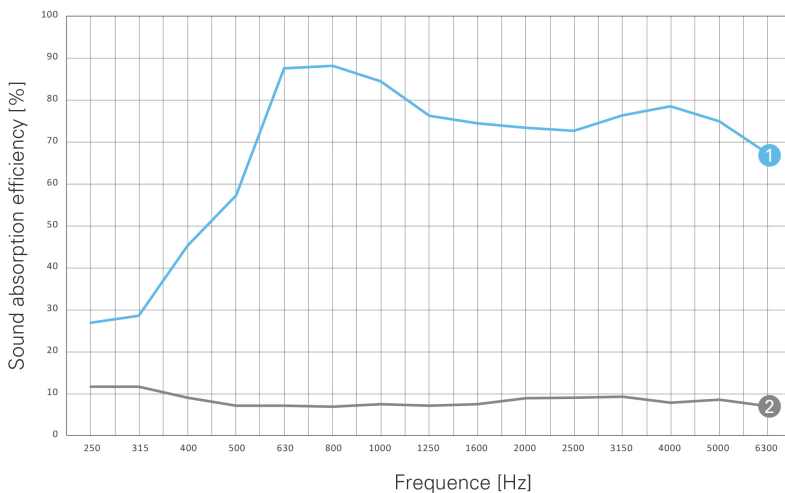

Sound absorption efficiency per octave according to ISO 354 of the HSC ceiling with acoustic insulation (1) and without (2)

About Halton Skyline

Halton Skyline is the first LED based lighting technology specifically developed for commercial kitchens. Everyone agrees

the light it provides is simply the closest possible to natural light. Halton Skyline is embedded in Halton's hoods, ventilated ceilings and hard false ceilings. Also available as standalone light fittings, its use can be extended to all areas of kitchens.



Halton Skyline represents a unique set of real benefits for the chefs, their staff and even their guests when it comes to display kitchens.

- A Culinary Light that remarkably respects the food colour and plasticity from raw ingredients to plated presentation
- A Culinary Light that also improves the working conditions while playing an active role in the kitchen safety
- A Human Centric light that follows your biorhythm to further improve the working conditions and staff Wellbeing
- A state-of-the-art lighting technology that, at its core, saves significantly on energy and

Description and dimensions

A Panel length max 2000 mm – **B** Panel width max 500 mm – **C** Flat healds width 100...400 mm
– **D** Suspension grid (X) max 2100 mm – **E** Suspension grid (Y) max 2000 mm – **F** Threaded rods height max 2000 mm

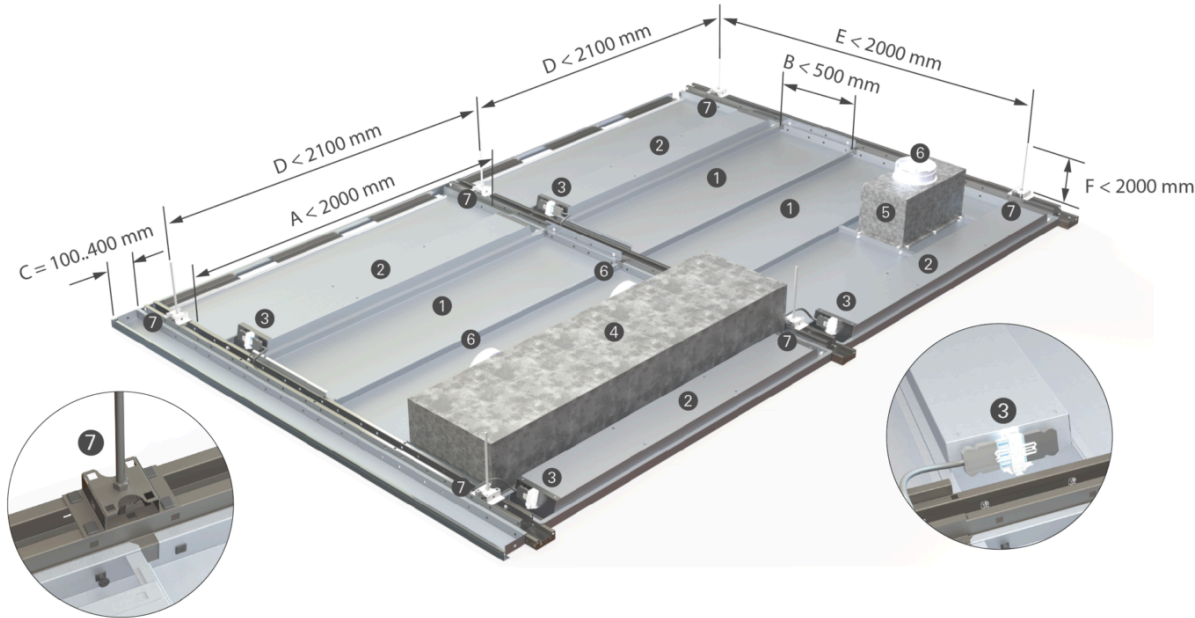

- 1 Panel or acoustic panel
- 2 Halton Skyline light fittings (500 / 750 / 10000 lx)
- 3 Light fitting connector (possibility of through wiring for the next light fitting)
- 4 Make-up air with Laminar Flow Units (LFU) (with honeycomb structure to prevent internal air recirculation)
- 5 Extraction Box (KBO) with high efficient FC filters
- 6 Connections to the ductwork
- 7 Suspension brackets / Threaded rods

"Lift & Slide"

