

**SBE-150**

**SBE-200**

**SBE-250**

**SBIE-150**

**SBIE-200**

**SBIE-250**

mod.	rango range °C	largo length (mm)	alto height (mm)	fondo depth (mm)	estantes shelves	capacidad latas cans capacity (33 cl.)	capacidad capacity (L)	voltaje voltage	refrigerante refrigerant	potencia frig. frig. power W	potencia power W
SBE/SBIE-150	+2°C +8°C	1465	820-880	530	4	320	325	230V-50Hz	R134a*	380	496
									R290	845	420
SBE/SBIE-200	+2°C +8°C	2005	820-880	530	6	500	490	230V-50Hz	R134a*	485	504
									R290	845	427
SBE/SBIE-250	+2°C +8°C	2545	820-880	530	8	680	650	230V-50Hz	R134a*	515	509
									R290	845	433

\*opcional - optional

Características técnicas y constructivas sujetas a variación sin previo aviso.

We reserve the right to change specifications without prior notice.

**SBE**

- Exterior en acero plastificado negro
- Interior en acero plastificado gris

**SBIE**

- Exterior en acero inoxidable
- Interior en acero plastificado gris

**CARACTERISTICAS COMUNES**

- Diseñados para bebidas y productos envasados
- Encastrables
- Doble cristal sobre marco abatible
- Estantes de alambre de acero plastificado, regulables en altura
- Compresor hermético alto par de arranque
- Evaporador sistema tiro forzado, con recubrimiento epoxi anticorrosión
- Control digital de temperatura, descarches optimizados, alarma por alta temperatura de condensación. Eficiente gestión del consumo de energía
- Iluminación interior LEDs
- Aislamiento de poliuretano inyectado, densidad 40 Kg/m<sup>3</sup>, bajo GWP y cero efecto ODP
- Pies regulables, con suplemento para altura 880 mm (incluido)
- Evaporación automática del agua de descarche
- Temperatura de trabajo a 32°C ambiente
- Tensión monofásica 230V - 50Hz

**SBE**

- Anthracite plastic coated steel exterior
- Interior gray plastic coated steel

**SBIE**

- Stainless steel exterior
- Interior gray plastic coated steel

**FEATURES IN COMMON**

- Designed for beverages and packaged products
- "Built-in" designed
- Double glass on folding frame
- Steel wire shelves adjustable plastic height
- Hermetic compressor higher starting torque
- Forced draft evaporator system with anticorrosion coating
- Digital temperature control, optimized defrost, high-temperature condensation alarm. Efficient management of energy consumption
- LEDs interior lighting
- Isolation of polyurethane, density 40 Kg / m<sup>3</sup>, zero ODP and GWP
- Adjustable feet, with suplement for height 880 mm (included)
- Automatic evaporation of defrost water
- Operating temperature 32°C ambient
- Voltage 230V - 50Hz

**OPCIONES**

OPCIONES	OPTIONS
set 6 ruedas	6 castors set
set 4 ruedas	4 castors set
230v 60Hz / 115v 60Hz	230v 60Hz / 115v 60Hz
motor lado izquierdo	left side engine
cambio a estante chapa inox	SS panel shelve increase
cambio R290 por R134a	R290 to R134a

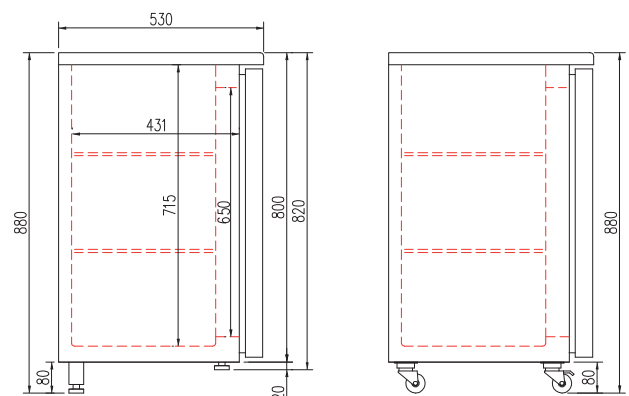
**SBE-200**  
 motor izquierda  
 left side engine

all photos must be considered as a reference - fotografías no contractuales



min 820 mm  
max 880 mm



SBIE-250



**SBE-150**  
estantes chapa inox opcional  
optional SS panel shelves